

## AZO lump breaker type KB 300 Q in cubic design

**Sturdy, compact  
design**

**Gentle crushing**

**Low-wear and  
energy-saving**

**Various  
construction  
materials are  
available**

### Preferred applications

The unit is used for crushing and milling of bulk materials with a tendency to form agglomerates, clods and lumps.

### Special advantages

The sturdy but compact design of the lump breaker, take care for a reliable and gentle crushing of clods and lumps. This unit is designed energy-saving and with low wear. It is available in various construction materials and surface finishings. Due to the pharmaceutical design it can be dismantled without tools and complies with highest requirements to hygiene and cleaning .

### Design

The AZO lump breaker consists of a sturdy housing with inlet and outlet flanges, crushing device and a laterally mounted gear motor. By means of an optional extraction device the shaft including screen and the gear motor can be extracted from the housing with low effort. The unit is available with the construction material no. 1.4301 or 1.4404 and various surface finishings including electrolytic polish.

## THE INNOVATION



### How it works

Bulk materials containing agglomerates, clods or lumps, are fed into the AZO lump breaker via the inlet. The product is crushed by the crushing device and transferred to the following production process via the passing sieve. The maximum grain size can be determined by means of the mesh size.

## Technical data

### Lump breaker type KB 300 Q without extraction device

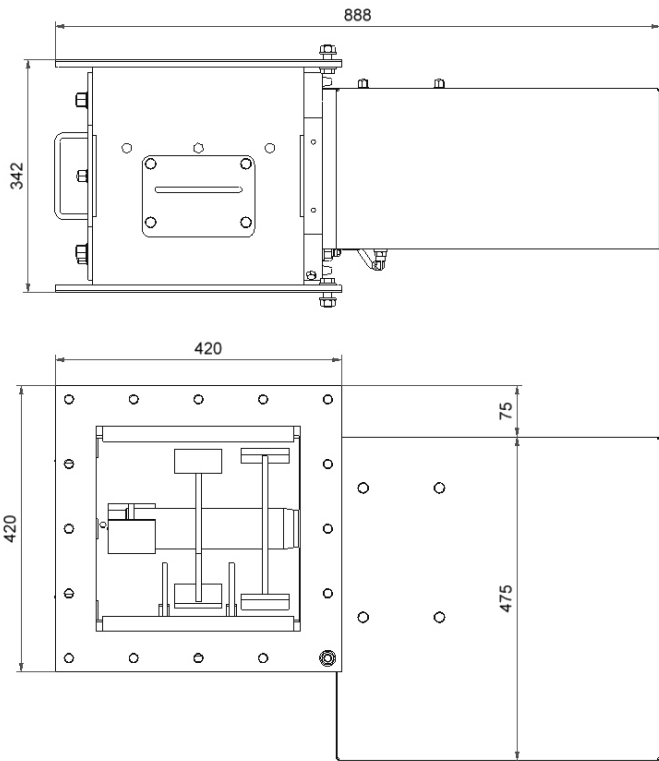

### Lump breaker type KB 300 Q quickly removable design (optional)

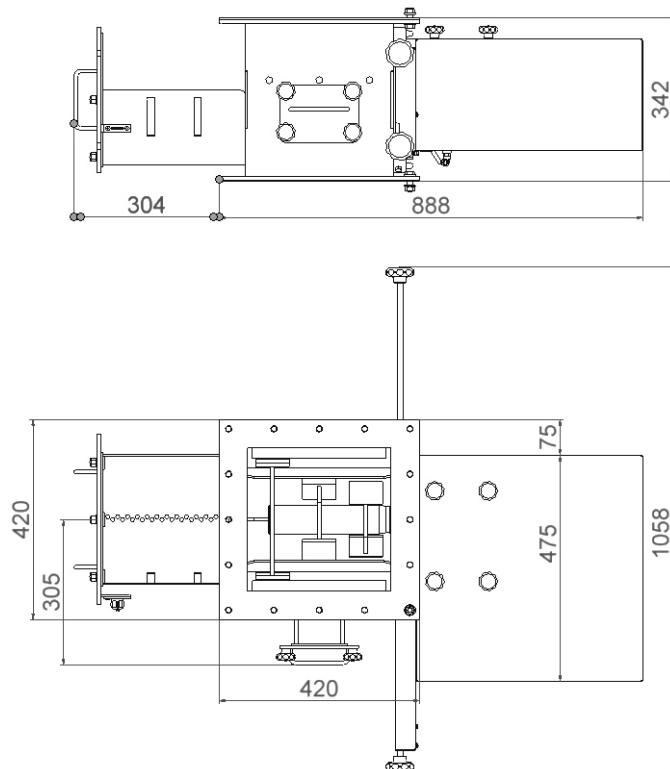

### Lump breaker type KB 300 Q:

Mounting position: horizontal  
 Weight: approx. 120 kg  
 Throughput capacity: depending on product  
 Product temperature: max. 80°C  
 Ambient temperature: 0 °C up to + 40 °C

#### Drive

Drive speed: 26 rpm (50 Hz)  
 32 rpm (60 Hz)

#### Three-phase motor

Output: 1.1 kW  
 System voltage: 220-242 V delta / 380-420 V star (50 Hz)  
 254-277 V delta / 440-480 V star (60 Hz)  
 Rated current: 4.45 / 2.55 A (50 Hz)  
 3.65 / 2.10 A (60 Hz)  
 Insulation class: F  
 Protection type: IP 54  
 Energy-efficient: IE2

#### Compressed air

Quality: free of water and oil  
 System supply: 6 bar  
 Operating pressure for the compressed air sealing: 2.0 at the fine pressure reduction  
 Consumption of the air sealing: 65 standard dm<sup>3</sup>/min

#### Construction material data:

Available with the materials 1.4301 or 1.4404 and various surface finishings including electrolytic polish.

### Lump breaker type KB 300 Q drive with rotor extractable, quickly removable design (optional)

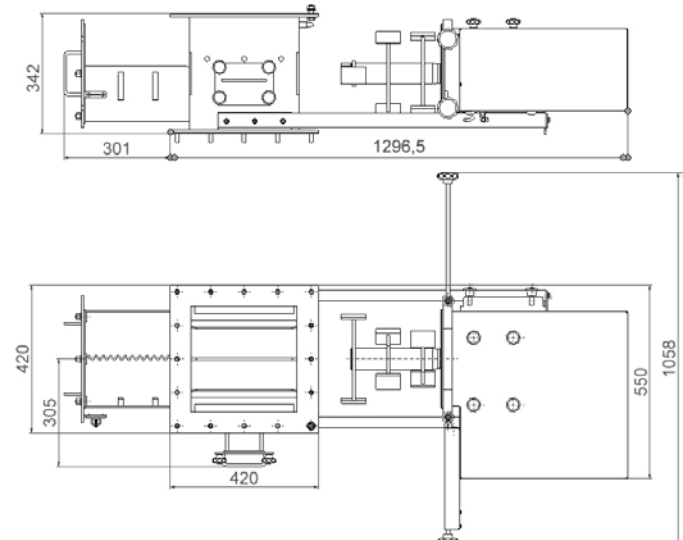

The design is subject to change due to our continuous improvement program.